

Eclipse Standardized Valve Train Segments

Series CE
Version 1

CE Standardized Valve Train Segments

Eclipse standard safety shut-off valve train segments are pre-piped and tested modules. They are ready for assembly with other piping components to meet the provisions of the EN 746-2 standard for a complete gas valve train. Please refer to EN 746-2 and Design Guide 791 for more information on additional components needed to meet the requirements.

Specifications	
Pipe Sizes	15 (1/2"), 20 (3/4"), 25 (1"), 40 (1-1/2"), 50 (2"), 65 (2-1/2"), 80 (3"), 100 (4"), 150 (6"), 200 (8")
Ambient Environment	Designed for typical indoor industrial applications
Ambient Temperature	-10°C to 60°C (+14°F to +140°F)
Ambient Humidity	5% to 95% relative humidity
Protection	IP54; NEMA 12
Process Fluid Media	Clean fuel gas such as natural (methane), propane, butane
Fluid Temperature	-15°C to 60°C (+5°F to +140°F)
Maximum Pressure	33 kPa (4.7 PSI)*
Electrical	120V or 230V, +10% to -15%, 50-60Hz

* Note: Maximum pressure for the complete assembly is based on a final test pressure at 150% of this rating. Refer to the individual component ratings for maximum operating pressures.

Component Details

Safety Shut-Off Valve Automatic, slow-opening, fast-closing, with over travel proof of closure switch, aluminum body, and CE approvals, IP54**

Parameters	Pipe Sizes			
	15–40 mm	50 mm	65–200 mm	65–200 mm (Actuator)
Maximum Operating Pressures	500 mbar (7 PSI)	1000 mbar (15 PSI)	700 mbar (10 PSI)	-10 to +60°C (+14 to 140°F)
Temperature Range	-40 to +65°C (-40 to +150°F)	-15 to +60°C (+5 to +140°F)	-15 to +60°C (+5 to +140°F)	-10 to +60°C (+14 to 140°F)

** Note: On 50 mm and above valves, the assembly can be converted from IP54 to IP65 with 2 of accessory p.n. 10021076, model AGA66.

High Gas Pressure Switch Automatic reset, 30-150 mbar (12-60"wc) settings, CE, IP54, 500 mbar (7 PSI) maximum operating pressure, -40 to +60°C (-40 to +140°F)

Component Details (Continued)

Low Gas Pressure Switch Automatic reset, 5-50 mbar (2-20"wc) settings, CE, IP54, 500 mbar (7 PSI) maximum operating pressure, -40 to +60°C (-40 to +140°F)

Flow Ratings

Flow at 10 mbar drop for low pressure, 0.64 specific gravity natural gas at 15°C

Size		Flow, m3/h	Flow, cfh
Millimeters	Inches		
15	1/2"	20	700
20	3/4"	24	845
25	1"	26	915
40	1-1/2"	65	2300
50	2"	125	4400
65	2-1/2"	215	7500
80	3"	300	10500
100	4"	500	17600
150 & 200	6" & 8"	950	33500

Gas Flows

For flows of a gas with a different specific gravity, use
 $Q_2 = Q_1 * \text{SQRT} (0.64/SG_2)$; where
 Q_2 = new flow
 Q_1 = flow from the table
 SQRT = square root function
 SG_2 = specific gravity of the new gas

For gas at a different temperature, use
 $Q_2 = Q_1 * \text{SQRT} (288/T_{abs2})$; where
 Q_2 = new flow
 Q_1 = flow from the table
 SQRT = square root function
 T_{abs2} = Absolute temperature of the new gas (273 + °C)

In the graph below, the bar represents the flow at which the velocity pressure is at the value of 1.25mbar (0.5"wc) for the pipe size. The diamond is the flow that produces 25 mbar drop in 30 m (10"wc per 100 feet) of the pipe size.

Capacity

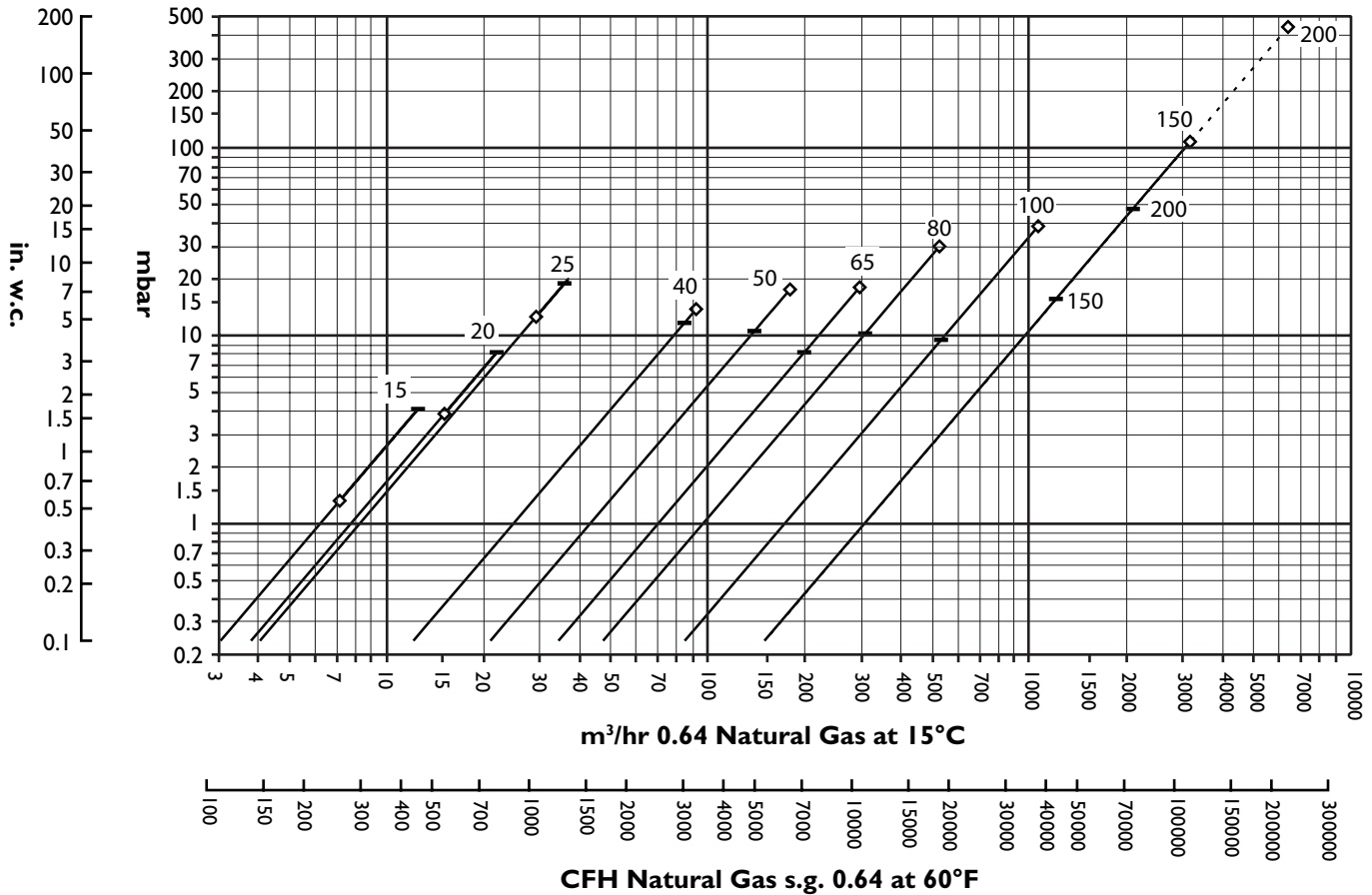

Dimensions

Part Number		Size	Length (A)	Clearance Length (B)	Clearance Height (C)	Depth (D)	Weight kg (lbs)
120V	230V						
10029410	10032039	15	354 (14)	489 (19)	363 (14)	123 (5)	4.42 (9.8)
10029413	10032040	20	364 (14)	540 (21)	375 (15)	124 (5)	4.62 (10.2)
10029415	10032041	25	373 (15)	531 (21)	360 (14)	123 (5)	4.83 (10.7)
10029417	10032042	40	461 (18)	670 (26)	416 (16)	156 (6)	6.24 (13.7)
10029419	10032043	50	598 (24)	786 (31)	428 (17)	233 (9)	12.6 (27.7)
10029421	10032044	65	691 (27)	922 (36)	544 (21)	251 (10)	43.1 (95.0)
10029423	10032045	80	732 (29)	1213 (48)	720 (28)	301 (12)	52.8 (116)
10029425	10032046	100	880 (35)	1303 (51)	720 (28)	337 (13)	73.0 (161)
10029427	10032047	150	959 (38)	1942 (76)	1250 (49)	384 (15)	180 (397)
10029429	10032048	200	1193 (47)	1678 (66)	567 (22)	343 (14)	138 (303)

Note: Pressure gauges are shown for reference and are not included in the assembly. The gage port has a pipe plug installed.

Sizes 15 – 40 mm (1/2" – 1-1/2"), BSP

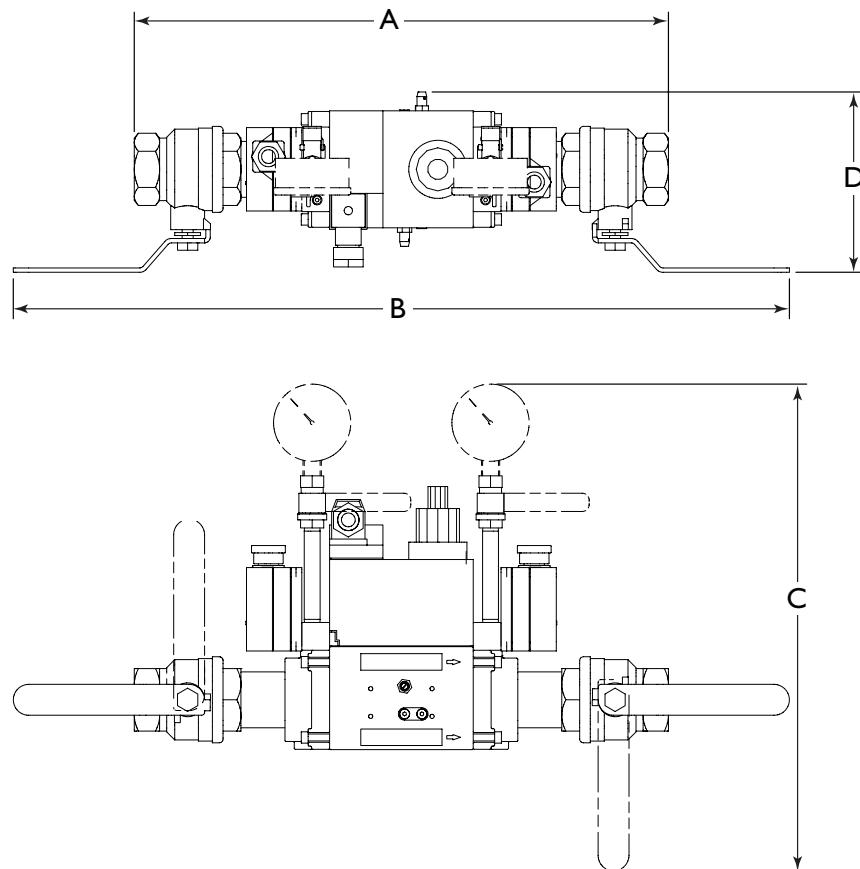

Dimensions

Note: Pressure gauges are shown for reference and are not included in the assembly. The gage port has a pipe plug installed.

Size 50 mm (2"), BSP

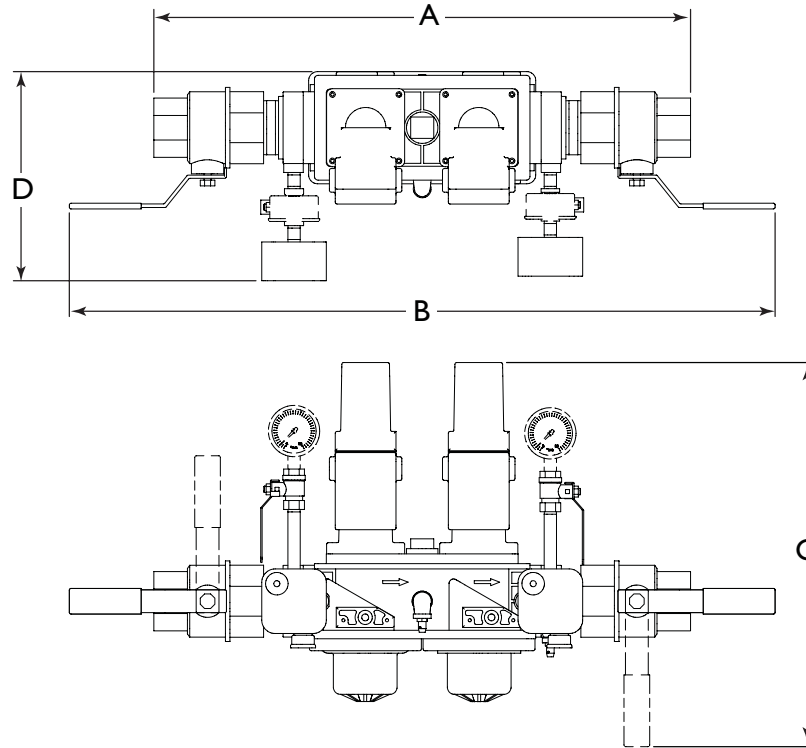

Sizes 65 – 200 mm (2-1/2" – 8"), DIN Weld Flange

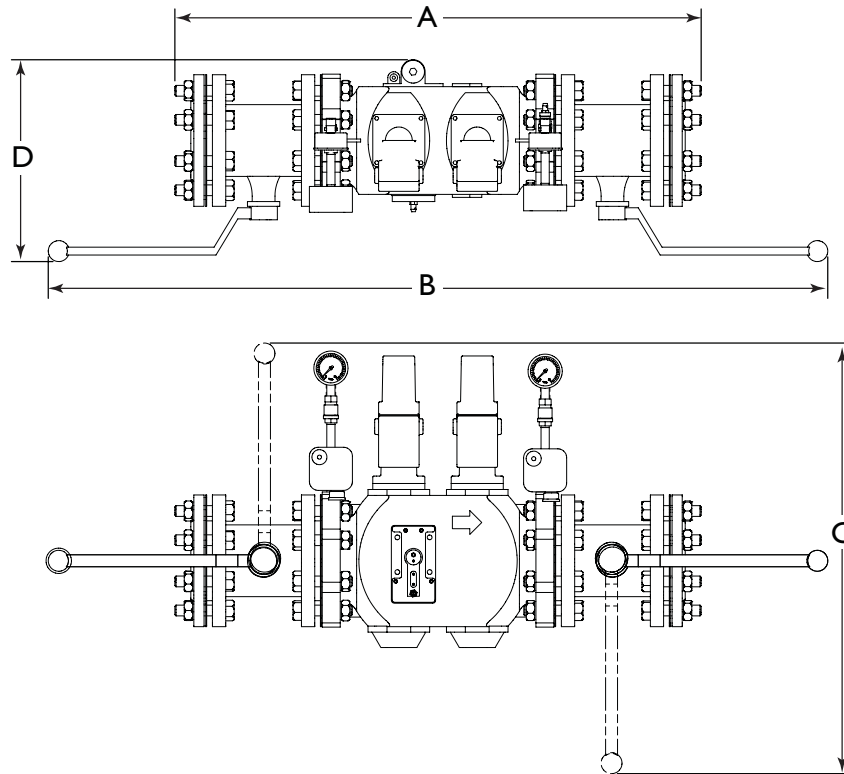



Offered By:

Power Equipment Company
2011 Williamsburg Road
Richmond, Virginia 23231
Phone (804) 236-3800
Fax (804) 236-3882

www.peconet.com